



LUND  
UNIVERSITY

# JobTech Dev – En Öppen Plattform för Digital Jobb- matchning och Vägledning

---

JOHAN LINÅKER, PHD



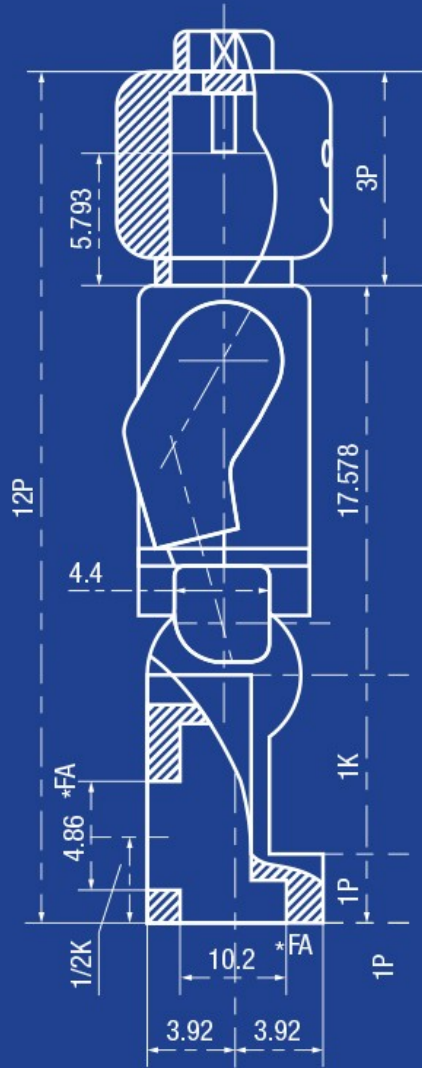
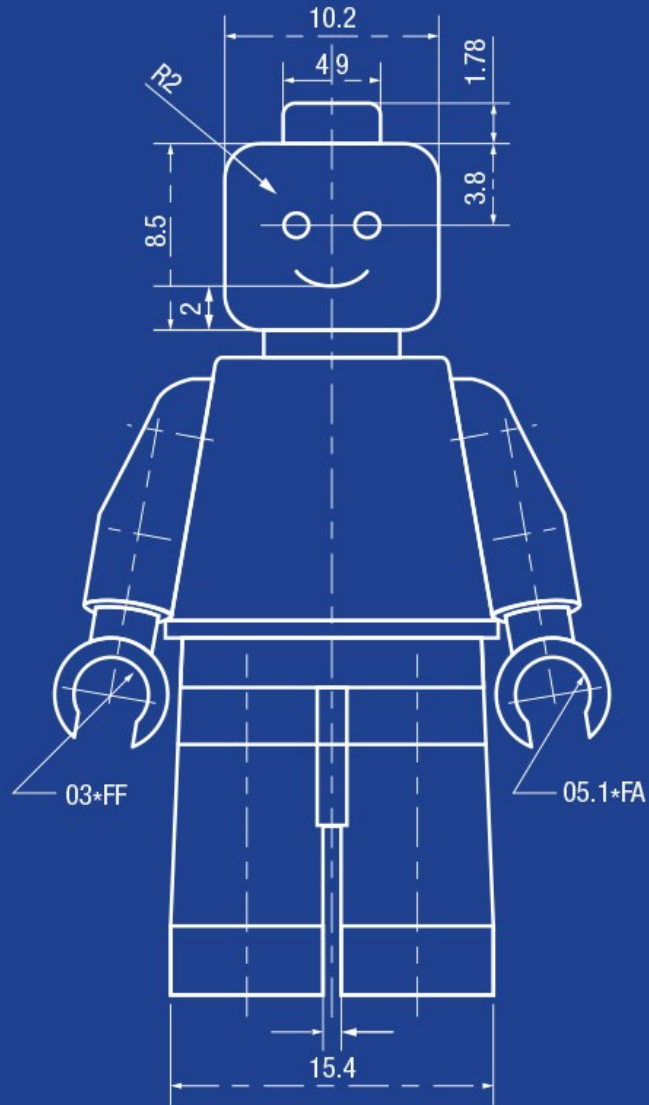

## Kort om Johan

Vad ska jag öppna upp? Varför? Hur?







”No matter who you are, most of the smartest people work for someone else” - Joy’s law



\*[https://en.wikipedia.org/wiki/Joy%27s\\_law\\_\(management\)](https://en.wikipedia.org/wiki/Joy%27s_law_(management))



A collection of glowing incandescent light bulbs hanging from above against a dark background. The bulbs are arranged in a cluster, with some in sharp focus and others blurred in the background. The light from the bulbs creates a warm, golden glow. The bulbs have brass-colored bases and clear glass envelopes. The text 'Öppen Innovation' is overlaid on a white rectangular box on the left side of the image.

# Öppen Innovation

Vad är en plattform?





Vad är ett ekosystem?



# Metafor från biologin











Plattformsledare och  
komplementärer





Ekosystemets hälsa





Androids ekosystem



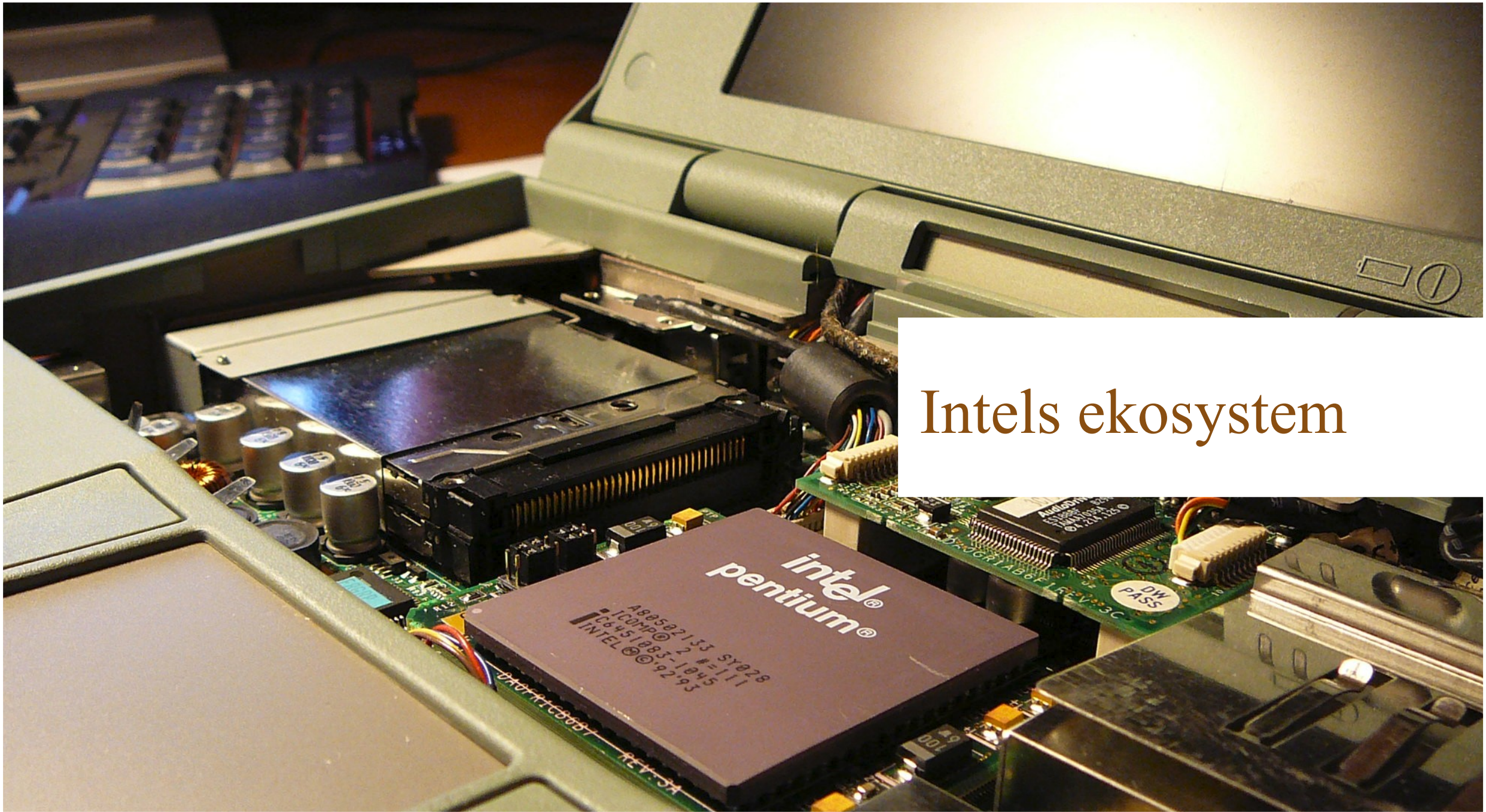

# Intels ekosystem





# Government-as-a-platform

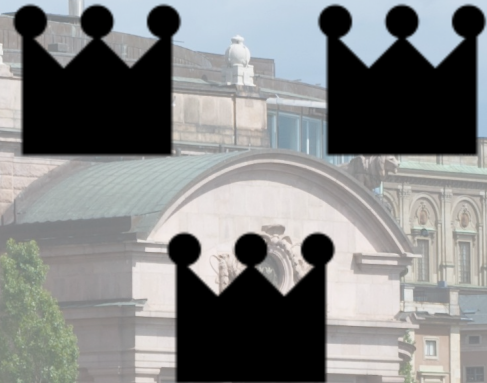



# Öppen Data







# Öppen Data

- Kvalitetsaspekter\*

- Maskinläslig
- Plattformsoberoende
- Avgiftsfri
- Öppen licens
- Komplet
- Omodifierad
- Tillgänglig
- Öppet format
- Länkad

\* <https://opendefinition.org/>  
<https://opengovdata.org/>  
<https://5stardata.info/en/>





# Öppen Data

- Utmaningar och hinder
  - Särskilt skyddsintresse
  - Kostnader för att öppna upp och underhålla
  - Tekniska hinder och kompetensbrist
  - Bristande incitament och kultur
  - Rädsla att stå till svars
  - Konkurrera med näringsliv
  - Veta vilken data som är efterfrågad
  - Få externa aktörer att utforska data

(Attard et al. 2015; Hossain et al, 2016; Safarov et al, 2017)





# Öppen Data

- Fördelar och drivkrafter
  - Ökad transparens
  - Ökad demokratiskt deltagande
  - Möjliggöra socialt och kommersiellt värdeskapande

(Attard et al. 2015; Hossain et al, 2016; Safarov et al, 2017)









# Öppen Källkod

- Utmaningar och hinder
  - Driva på utveckling och innovation
  - Ej konkurrera med näringsliv
  - Rädsla att stå till svars
  - Kostnad för att generalisera, bidra och underhålla källkoden
  - Undersöka och bygga externt intresse

(Linåker and Regnell, 2019)





# Öppen Källkod

- Fördelar och drivkrafter
  - Delat underhåll och kvalitetsarbete
  - Ökad innovation och utvecklingstakt
  - Ökad transparens och förtroendebyggande
  - Större inkludering i upphandlingar
  - Ökad konkurrens på marknaden
  - Resultat fler till gagn

(Linåker and Regnell, 2019)



# JobTech Dev



Google

VISMA

ReachMee

LinkedIn

ASSESSIO



JobTech Development Extensions  
(Öppen Data och Öppen Källkod)



IOII  
OOI





# JobTech Dev



Google

VISMA

ReachMee

LinkedIn

ASSESSIO



JobTech Development Extensions  
(Öppen Data och Öppen Källkod)



1011  
001

JobTech Taxonomy

A文





Google

VISMA

ReachMee

LinkedIn

ASSESSIO



JobTech Development Extensions  
(Öppen Data och Öppen Källkod)



JobTech Dev

JobTech Jobs





# JobTech Dev



Google

VISMA

ReachMee

LinkedIn

ASSESSIO



JobTech Development Extensions  
(Öppen Data och Öppen Källkod)



1011  
001

JobTech MyData





# JobTech Dev



Google

VISMA

ReachMee

LinkedIn

ASSESSIO



JobTech Development Extensions  
(Öppen Data och Öppen Källkod)

JobTech Search











Kan JobTech Dev generaliseras?







”If most of the code comprising your product or service isn’t open source software, it’s highly likely that you’re wasting effort and cash reinventing the wheel.”

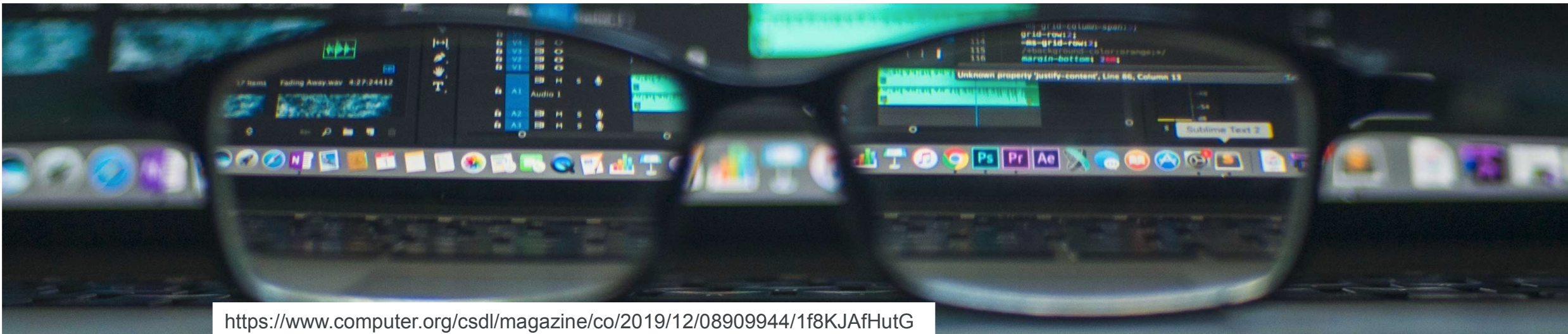





Vi kan och bör lära av varandra



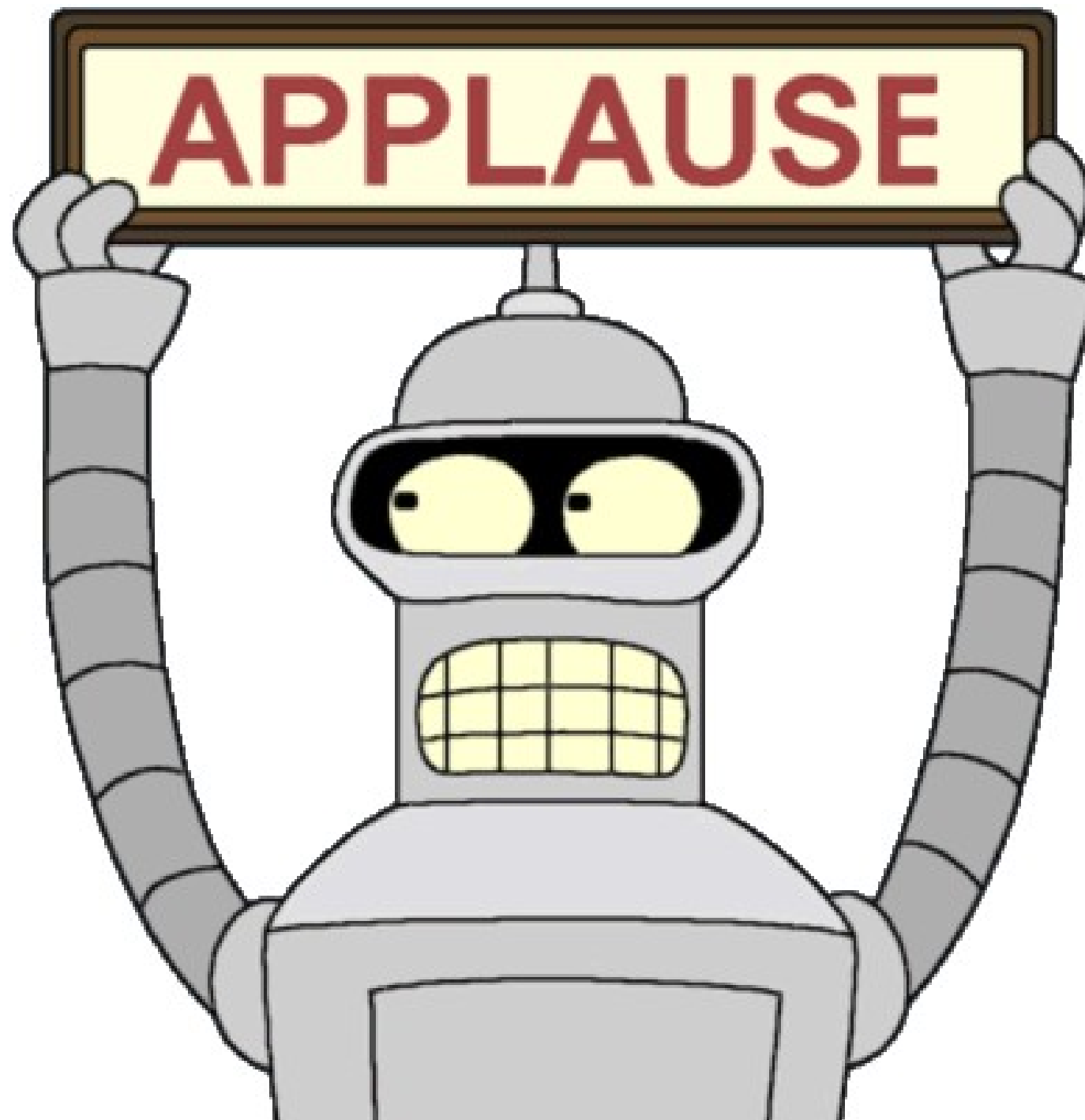





**LUND**  
UNIVERSITY